

Wine Cooler

Instruction Manual

P39AD2D40

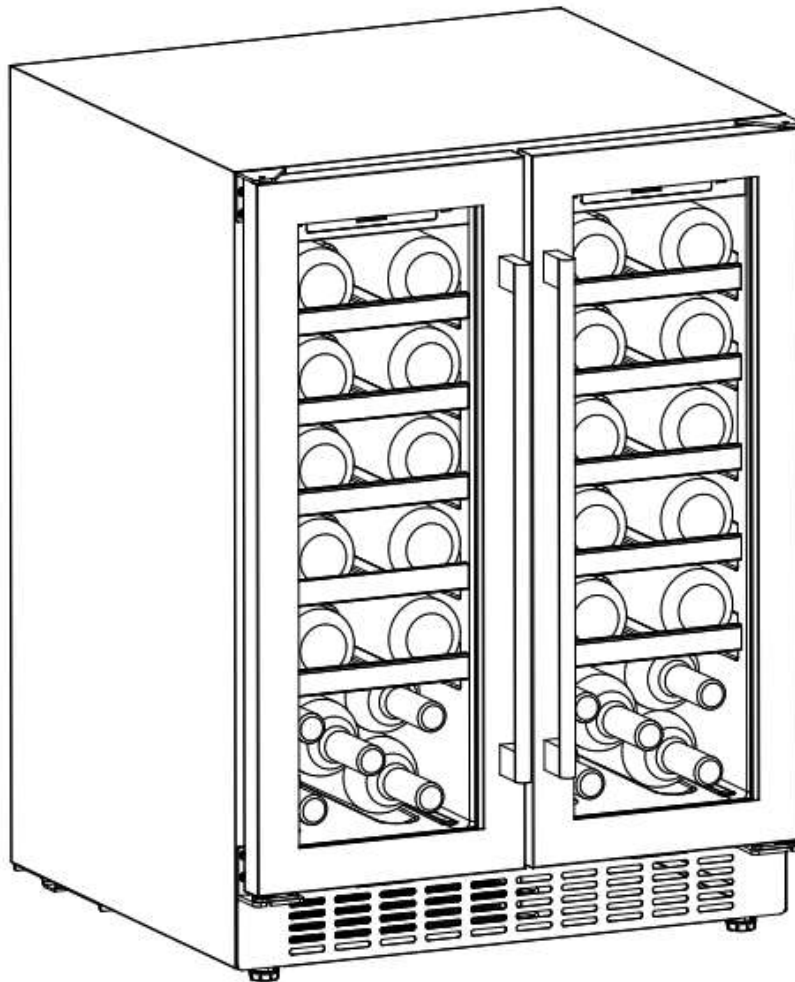

NOTE: Thank you for your purchase of the wine cooler ! This product is used to chill red wine. Our product will create perfect temperature and humidity environment to store your collection of wine quietly and peacefully.

Content

Safety instructions & warnings.....	1-2
Installation.....	3
Description of the appliance.....	4
Operation.....	5
Troubleshooting.....	8
Maintenance and cleaning.....	8
Technical parameters.....	9
Environmental protection.....	9
Warranty	11

Safety instructions & warnings

Your safety is of the utmost importance to our company. Please make sure that you read this instruction booklet before attempting to install or use the appliance. If you are unsure of any of the information contained in this booklet, please contact the Technical Department.



Prohibition



Warning



Caution



Caution

- This appliance can be used by children aged from 8 years and above and persons with reduced physical, sensory or mental capabilities or lack of experience and knowledge if they have been given supervision or instruction concerning use of the appliance in a safe way and understand the hazards involved. Children shall not play with the appliance. Cleaning and user maintenance shall not be done by children without supervision.
- Children aged from 3 to 8 years are allowed to load and unload refrigerating appliances. Children should be supervised to ensure that they do not play with the appliance.
- This appliance is intended for **HOUSEHOLD USE ONLY** and not for commercial or industrial use.
- This appliance is intended to be used exclusively for the storage of wine.



Warning

- Keep ventilation openings, in the appliance enclosure or in the built-in structure, clear of obstruction.
- Do not use mechanical devices or other means to accelerate the defrosting process, other than those recommended by the manufacturer.
- Do not damage the refrigerant circuit.
- Do not use electrical appliances inside the storage compartments of the appliance, unless they are of the type recommended by the manufacturer.
- Make sure that the appliance is connected to power supplying accordance with the rating label.
- Use an independent grounded socket with 10A or higher, do not connect to transformer or socket with multiple outlets.
- Make sure socket is grounded properly and do not modify power cord & plug.
- Connect power plug with socket firmly in case of possible risk of fire.
- Plug should be within reach for easy disconnection after the appliance positioned in case of accidents occurred.
- Do not store or burn gasoline or other inflammables near the appliance in case of possible fire.

- Do not store inflammables, explosives, acid & alkaline liquids etc. in the compartment of the appliance.
- Do not operate other appliances in the compartment.

Child Safety

- Do not allow child play inside the appliance in case of entrapment.
- Do not allow child hang on the door to play in case of falling of the appliance.
- Do not allow child reach into compressor compartment or touch metal components at rear of the appliance in case of possible injury.

Keep away from water.

- Do not spray water on the appliance or wash the appliance by pouring or filling water in case of invalid insulation and possible electric shock.

Be careful of freezing.

- Do not touch surface of the liner inside the compartment, especially with wet hand, in case of frozen injury while the appliance is in operation.

Do not open the door for long periods.

- Opening the door for long periods can cause a significant increase of the temperature in the compartments of the appliance.

Modification of the appliance not allowed.

- Do not reconstruct the appliance by yourself which might cause damages to the appliance.

Unplug the appliance under certain conditions

- Unplug the appliance before cleaning & maintenance.
- Unplug the appliance when power cut occurred.

Disposal of the appliance

- Please according to local regulations regarding disposal of the appliance for its flammable refrigerant and blowing gas.
- Before you scrap the appliance, please take off the doors to prevent children trapped.
- Send the appliance to the designated disposal location.

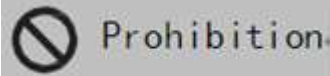

Do not damage the power cord.

- Do not disconnect the appliance by pulling power cord rather than pulling the plug.
- Do not set the appliance above the power cord or step on the cord intentionally.
- Put the power cord at right place when moving the appliance.

When the power cord is damaged

- Do not use damaged power cord, and get it replaced immediately by manufacturer service agent or by qualified electrician.
- If needed, extend the power cord with cord of 0.75mm² or bigger by qualified electrician.

Installation

Position

- ⚠ Do not lean the appliance over 45° when moving it to position.
- ⚠ The appliance must be put on flat, firm & dry floor or similar non-combustible pad; do not use the package foam pad.
- ⚠ Do not put the appliance in the wet place.
- ⊘ Do not use the appliance in the frozen place.
- ⊘ Do not use the appliance outdoor in case of sunlight or rain.

The appliance is designed to either build under the counter or stand alone on the floor.

Demonstration for building under the counter:

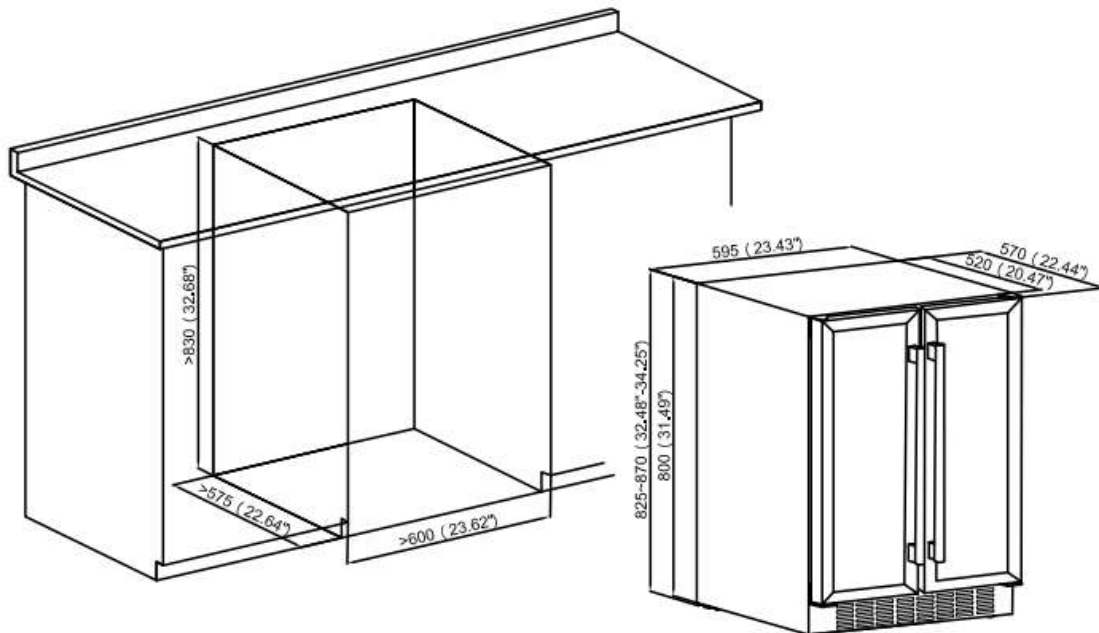

Wine bottles could be stored when you feel cooling inside after the appliance operates around 1 hour.

Description of the appliance

Accessories & name

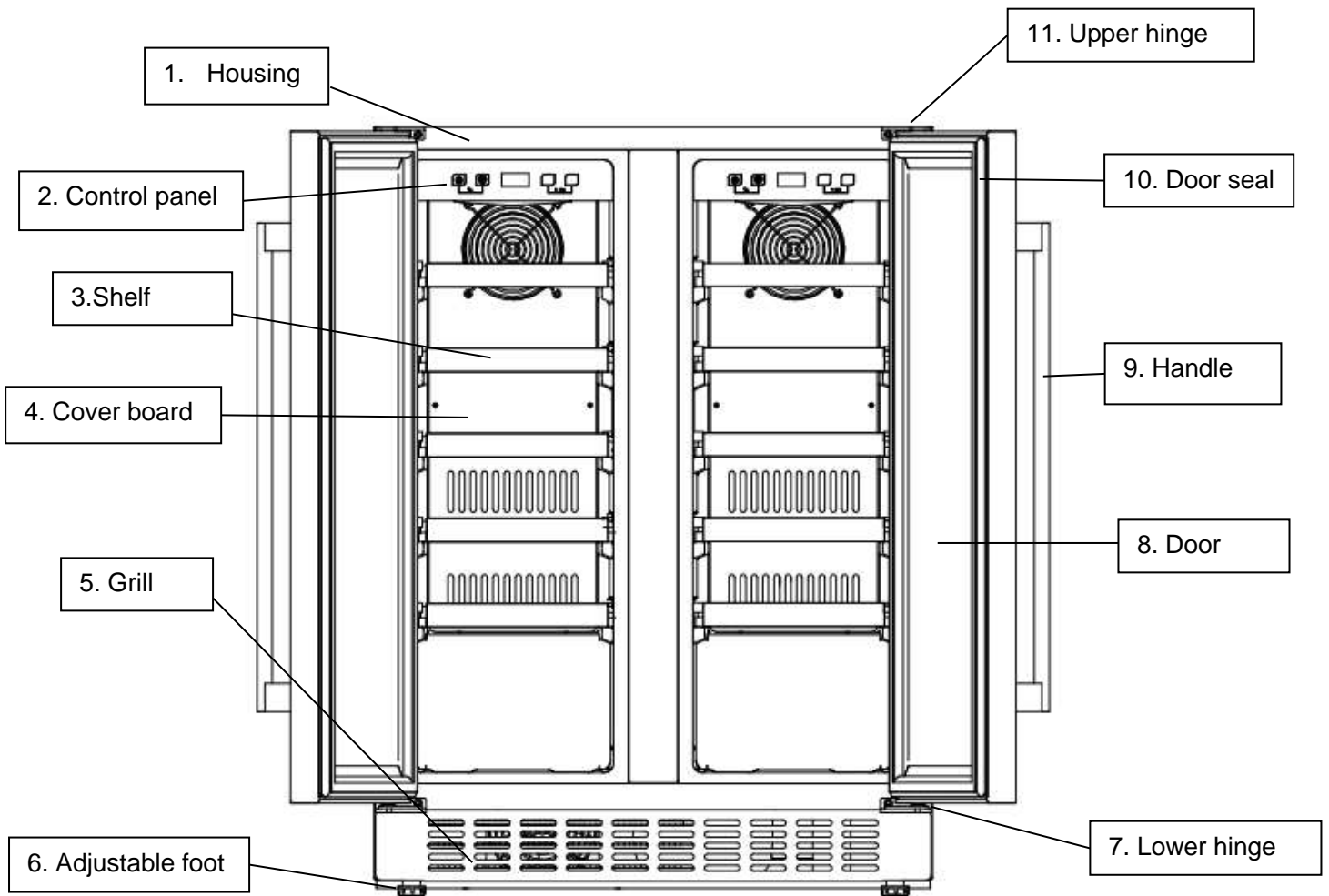

Note: Shelves, door frame, handle and other accessories could be different according to different models and configuration. All photos in this manual are for reference. The appliance you buy might not be exactly the same as shown here. Please refer to the actual product.

Installing the handle and reversing the door of wine cooler

1. Install handle to the door frame of the appliance.

The handle is delivered in a separated package with screws together inside the carton.

① Reveal two small holes on the door frame from inner side by pulling out a bit the door seal ② Aim the handle to the holes and insert the screws from inside

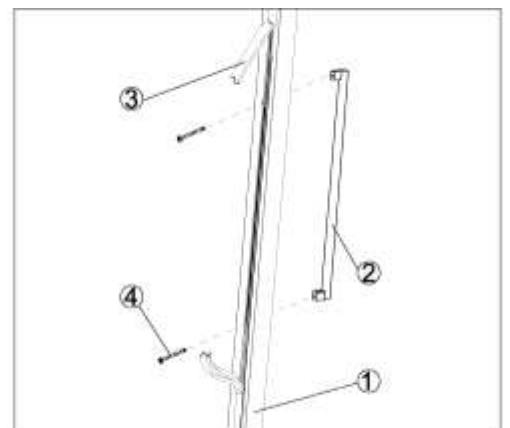

- ③ Screw them up with screwdriver ④ Put back door seal to cover the screws.

Operation

Start operation.

1. Cleaning the compartment

Before power on, clean inside of the appliance and check the drainage pipe in good connection. (For details, please refer to the “Maintenance and cleaning”)

2. Put the appliance still

Before power on, level the appliance on the firm & dry floor for at least 30 minutes.

3. Power on

The appliance start operation and it will cool down inside after 1 hour, otherwise you should check the power connection.

Control panel

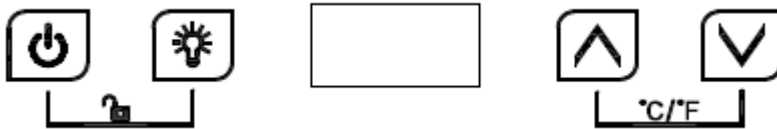

All keys would be invalid in lock mode. Please unlock first.



ON/OFF

1. Keep pressing the key 3 seconds, power down, goes to stand-by mode.
2. Keep pressing the key again 3 seconds to return back to normal working.



Light

Press the key, turn on or turn off the LED lights inside. In stand-by mode, the key is invalid.



UP

Press the key once, LED Display in regular flash showing current set temperature. Continue pressing to adjust set temperature, one press increase 1°C. Regular flash quit after 5 seconds detecting no press and new set temperature save. LED display return to show actual temperature inside.



Down

Press the key once, LED Display in regular flash showing current set temperature. Continue pressing to adjust set temperature, one press reduce 1°C.

Regular flash quit after 5 seconds detecting no press and new set temperature save. LED display return to show actual temperature inside.



Child Lock (Combination key)

1. Lock: Press both keys at the same time for 3 seconds to lock.
2. Unlock: Press both keys at the same time for 3 seconds to unlock.



Fahrenheit / Celsius display interchange

Switch temperature display between Fahrenheit and Celsius by pressing both keys at the same time for 2 seconds.



Attention

1. The left cooling temperature could be set from **2 to 20 °C**. The right cooling temperature could be set from **5 to 20 °C**
2. Alarm sound: when the system malfunction occur and alarm sound, press any key on the control panel to cancel the alarm sound.
3. Temperature sensor failure:
 - When the temperature sensor of left zone failure occur, error code displays: E1 for open circuit; E2 for short circuit.
 - When the defrost sensor of left zone failure occur, error code displays: E3 for open circuit; E4 for short circuit.
 - When the temperature sensor of right zone failure occur, error code displays: E5 for open circuit; E6 for short circuit.
 - When the defrost sensor of right zone failure occur, error code displays: E7 for open circuit; E8 for short circuit.
4. Climate Class:
 - extended temperate: 'this refrigerating appliance is intended to be used at ambient temperatures ranging from 10 °C to 32 °C'
 - temperate: 'this refrigerating appliance is intended to be used at ambient temperatures ranging from 16 °C to 32 °C'
 - subtropical: 'this refrigerating appliance is intended to be used at ambient temperatures ranging from 16 °C to 38 °C'

Wine storage

- ✧ The appliance equips with sufficient independent shelf to allow your collection of wine get mature quietly and peacefully.
- ✧ Left full wooden shelves loading capacity: **20** bottles. (standard Bordeaux with 750ml)

- ✧ Right full wooden shelves loading capacity: **20** bottles (standard Bordeaux with 750ml)

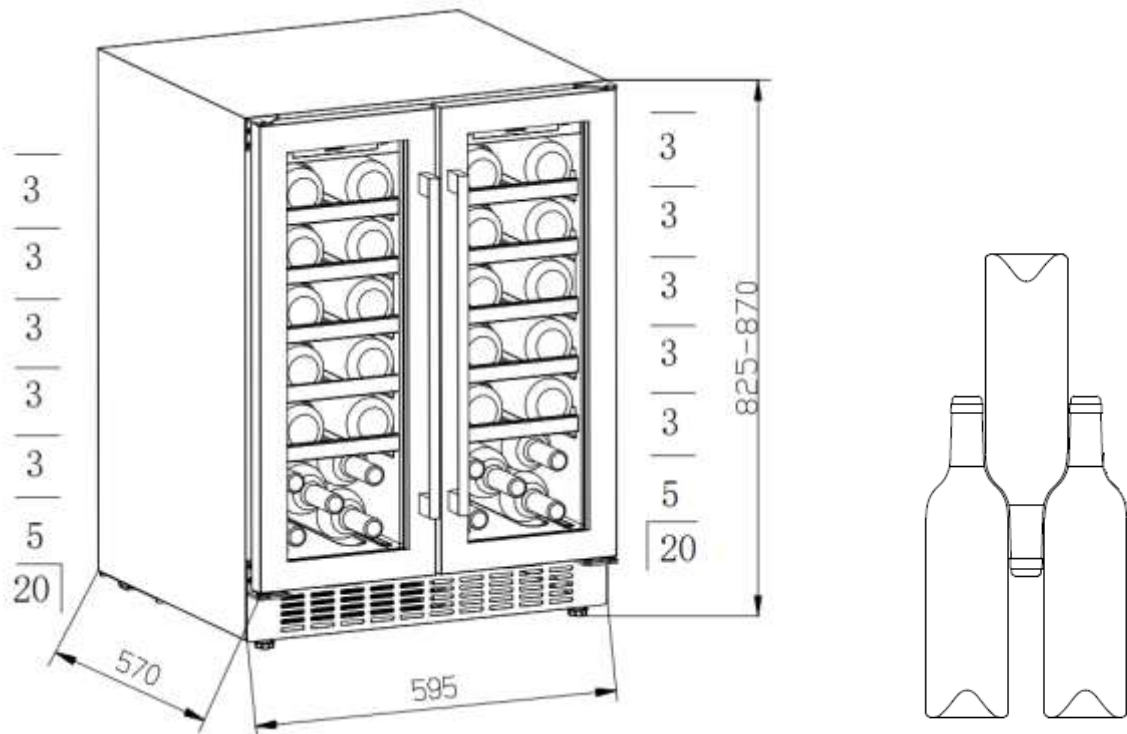

Bottle arrangement

- ✧ Loading capacity will vary in terms of different way of bottle arrangement or different bottle sizes.
- ✧ Each shelf is designed to put on 1 or 2 layers of wine bottles. More than 2 layers of bottle arrangement on one shelf are not recommended.
- ✧ Each shelf could pull out partly to store wine bottles easily.
- ✧ Open the door straight enough before pulling out shelves.
- ✧ If the wine cooler would have no load for a long time, it is recommended to power it off, clean it carefully, and open the door for ventilation.
- ✧ Below table is the recommended temperature for wine storing & drinking:

Red Wine	15-18°C
White Wine	9-14°C
Rose wine	10-11°C
Champagne & sparkling wine	5- 8°C

Troubleshooting

The appliance makes lots of noise?	<ul style="list-style-type: none"> ● Please adjust the front foot, keep the appliance leveling. ● Please keep the appliance a bit space from walls.
Liquid flowing sound inside the cabinet?	<ul style="list-style-type: none"> ● It is normal because of the refrigerant working inside.
The appliance does not start?	<ul style="list-style-type: none"> ● Make sure the appliance is connected to the power properly. ● Make sure switch on the power. ● The compressor re-starts after 5 minutes for a power cut.
Compressor runs continuously?	<ul style="list-style-type: none"> ● If no cold is being produced, call the after-sale service.
Door does not seal tightly?	<ul style="list-style-type: none"> ● After long time use, the door seal might get stiff & distorted partially. <ol style="list-style-type: none"> 1. Heat the door seal with hot-wind blower or hot towel. 2. The door seal get softened and close the door.
The appliance does not cool sufficiently?	<ul style="list-style-type: none"> ● Please adjust temperature setting. ● Keep the appliance away from sunlight or heat. ● Please do not open the door frequently.
Unpleasant smells inside cabinet?	<ul style="list-style-type: none"> ● A little bit plastic smell for newly-buy appliance is normal and will disappear after a short time. ● Clean the compartment and ventilate it for a few hours.
Condensate on the glass door?	<ul style="list-style-type: none"> ● Please do not open the door frequently or for a long time. ● Please do not set the temperature too low. ● High ambient temperature and humidity would cause condensate.
The light is not working?	<ul style="list-style-type: none"> ● Check the power supply first. ● Call the retailer's after-sale service if the light is broken.

Maintenance and cleaning

Cleaning

- Disconnect the appliance before cleaning.
- Clean the appliance with soft cloth or sponge by water.
- Do not use organic solvents, alkaline detergent, boiling water, washing powder or acid liquid etc.
- Do not flush the compartment of the appliance.
- Clean regularly surfaces that can come in contact with accessible drainage systems.

The below items will damage the surface of wine cooler:

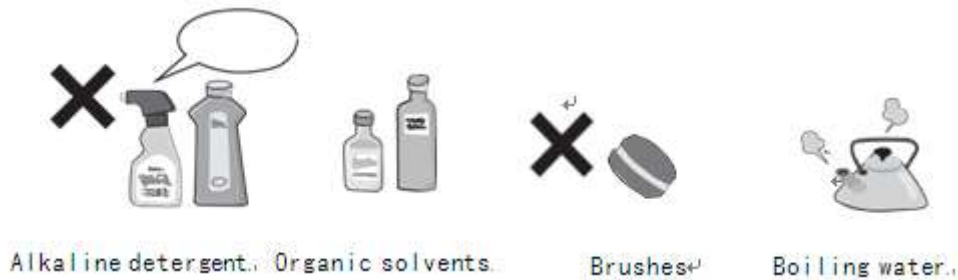

Power cut

Most power cuts could be resolved within a short time. To protect your wines during a power cut, avoid opening the door as much as possible. During very long power cuts, take the necessary measures to protect your wine.

Out of service for long time

Remove all bottles from the appliance, switch off, defrost, clean, dry, and leave the door open to prevent mould developing within the appliance.



If the appliance is disconnected or if there is a power cut, you must wait at least five minutes before re-starting.

Moving the appliance

- Cut off the power supply and unplug the appliance.
- Remove all bottles from the appliance.
- When moving the appliance, do not lean the appliance over 45°.



Technical parameters

Product model	P39AD2D40
Voltage/frequency	220-240V/50Hz
Refrigerant/weight	R600a/32g
Effective volume	112L
Loading capacity	20+20bottles
Net weight	42.8kg
Unit dimension (WxDxH)	595×570×820mm
Packing dimension (WxDxH)	660x625x880mm

Remarks:

1. The Net weight includes shelves and the Unit dimension is without handle on the door.
2. The manufacturer reserves all the rights to change the above parameters without prior notice. Please refer to the nameplate of your appliance.
3. Loading capacity will vary in terms of different way of bottle arrangement or different bottle sizes (standard Bordeaux with 750ml is applied here).
4. The product height could be adjusted from 825 to 870mm by 4 plastic feet.

ENVIRONMENTAL PROTECTION

Do not dismantle the appliance in a way which is not shown in the user manual. The appliance could not be dismantled by user. At the end of life, the appliance should not be disposed of with household waste. Check with you Local Authority or retainer for recycling advice.



This appliance is marked according to the European directive 2012/19/EU on Waste electrical and Electronic Equipment (WEEE). By ensuring this product is disposed of correctly, you will help prevent potential negative consequences for the environment and human health, which could otherwise be caused by inappropriate waste handling of this product.



POWERPOINT STANDARD MANUFACTURER WARRANTY TERMS AND CONDITIONS

This appliance was supplied by Shomar Ltd, Dublin. Combining years of knowledge and experience with our commitment to producing high quality appliances is what make us the country's best, fully Irish owned, Domestic Appliance Distributor. We provide all after sales service from our Headquarters in Dublin.

12 Month Warranty

This Warranty is for 12 Months from Date of Purchase and covers both Parts & Labour. Any complaints that occur during normal use of these appliances will be repaired free of charge provided the appliance has been used and maintained in accordance with the Terms and Conditions.

If a repair to your appliance is necessary evidence of purchase will be required for a call to be covered by your Warranty.

Two-year Warranty

To avail of the second year free warranty you must register your new appliance with Shomar Ltd. Registering your appliance will also allow us to contact you in the unlikely event that a modification is required. In case of an insurance loss such as theft, fire or flood, your registration will serve as proof of purchase. Scan our QR to register your warranty -



www.powerpointappliances.ie

Terms and Conditions

The Warranty only covers the appliance for use in a normal domestic environment. Institutional use or commercial use is not covered. (To obtain a commercial Warranty on your appliance contact us on service@shomar.ie for more details)

The following is not covered by the Warranty:

- Complaints due to the use of incorrect voltage.
- Failure of the water supply
- Failure of the electricity supply
- Failure to operate the appliance in line with the guidelines set out in the instruction manual.

- Damage to the appliance or its components however caused.
- Consumable items. E.g. Fuses, bulbs, broken glass, Knobs, Plastics.
- Blockages of Filters, drainage systems, soap dispensers etc

Note:

- Repairs or modifications carried out by anyone other than Shomar authorised agents will deem the Warranty Null and Void. Please visit www.powerpointappliances.ie to obtain information on authorised agents.
- All Gas appliances must by law be fitted by a Registered Gas Installer. For further details see WWW.RGI.IE
- Built In appliance installation and reversing the door hinges must be undertaken by a competent person.
- If in any doubt about the installation of our domestic appliances please email us for more details.service@shomar.ie

How to log a service call:

If in the event you need to log a service call for your appliance you can contact our service department on Ph: 01-4505327 (during working hours)

Email service@shomar.ie

Go online www.powerpointappliance.ie

This Warranty does not in any way diminish or affect your statutory rights in connection with the product. This Warranty is in addition to your statutory rights as a consumer. If you have any questions about these rights, please contact the retailer from which you purchased the product. In certain circumstances, it is possible that your statutory rights may offer additional or higher levels of protection than those offered under the terms of this Warranty.

This Warranty applies only to the cost of repairing the product. To the extent permitted by law, the Manufacturer does not accept and will not be held liable for any financial loss incurred in connection with the failure of any product to operate in accordance with the expected standards. Such financial loss includes but is not limited to loss arising from:

- Food Loss
- Time taken from work
- Damaged clothing or other items
- Laundry costs
- Meals from Restaurant /Takeaways
- General Compensation for Inconvenience

Does PowerPoint offer replacements?

This is a repair-only Warranty. On occasion, the Manufacturer may at its sole discretion, replace your product with a new product instead of carrying out a repair. In the unlikely event we cannot repair your appliance it will be replaced free of charge, replacement will be authorised and provided by the retailer upon contact from the manufacturer.

Any costs related to disconnecting the faulty product and installing the replacement product will not be borne by the Manufacturer unless previously agreed to in writing. The original Warranty will continue to apply to the replacement product; the new product will not come with a new Warranty.

Will I be charged for the repairs?

It is the responsibility of the consumer to provide proof of purchase to the Engineer to ensure your product is covered by this warranty. The Manufacturer reserves the right to charge for service call if:

- You cannot provide proof of purchase that your product is covered by this Warranty.
- The engineer finds that there is no fault with your product.
- That your product has not been installed or operated in accordance with the User Manual.
- That the fault was caused by something other than faulty materials, defective components, or manufacturing defects.
- For missed appointments.

Payment is due immediately upon the Engineer providing you with an invoice. The Manufacturer reserves the right to terminate the Warranty if you fail to pay the costs for the service call.

The spare part availability of this appliance is 10 years. During this time, original spare parts will be available to operate the appliance properly.

This appliance was supplied by Shomar Ltd Dublin. If you would like to contact us in relation to your product for service or spare parts we can be contacted on 01-4505327 or service@shomar.ie.

The model information as stored in the product database can be reached by scanning the below QR Code or by visiting <https://eprel.ec.europa.eu/> and entering the following registration number: 2034053

