

PowerPoint

MODEL P85050EMI

Built In 50/50 55cm Wide
Fridge Freezer
Instruction Manual



**IMPORTANT:
RETAIN FOR FUTURE REFERENCE**

Contents

Safety Instructions	3-4
Electrical Safety	4
Transportation & Handling	5
Installing & Switching on your Appliance	5
Before Switching On	6
Product Overview	7
Unit & Spare Parts	7
Usage	8-9
Temperature Selection	8-9
Installation	10 - 18
Door Reversal	19-22
Replacing the Light	22
Energy Saving Advice	23
Freezer Storage Advice	23
Power Failure	24
Maintenance & Cleaning	25-26
Internal Cleaning	25
External Cleaning	25
When the appliance is not in Use	25
Defrosting	26
Trouble Shooting	27-28
Connection to the Mains Supply	29
Guarantee	30
Technical Specification	31

Safety Instructions

Important note: Please read this booklet before installing and switching on this appliance. The manufacturer assumes no responsibility for incorrect installation and usage as described in this booklet.

- This model uses natural refrigerant gas as part of its cooling system. This gas is known as R600a (Isobutene) and is environmentally friendly but can be combustible. Care should therefore be taken when handling or transporting the product to ensure that none of the refrigeration circuit components are damaged,
- Do not obstruct ventilation openings in the appliance
- The appliance must not be placed or rested on its power cord.
- Do not use mechanical devices or other artificial means to accelerate the defrosting process, such as a heater or a hair dryer.
- Do not use electrical appliances in the refrigerator compartment of the appliance.
- If this appliance is to replace an old refrigerator with a lock, the lock must be removed as a safety measure before storing it or disposing of it. This is to protect children from locking themselves inside the appliance.
- Old refrigerators and freezers contain insulation gases and refrigerant, they must be disposed of properly. Contact your local authority or your dealer if you have any questions. Please ensure that you do not damage the scrap unit prior to being picked-up by the relevant waste disposal service.
- Do not use adaptors or extension leads when connecting the appliance to the electrical power supply
- Do not plug in damaged plugs
- Do not pull, twist or damage the power cable.
- Do not plug-in or un-plug the appliance with wet hands to prevent electrical shock.

- This appliance can be used by children aged from 8 years and above and persons with reduced physical, sensory or mental capabilities or lack of experience and knowledge if they have been given supervision or instruction concerning use of the appliance in a safe way and understand the hazards involved. Children should not play with the appliance.
- This appliance is designed to be used by adults, do not allow children to play with the appliance or let them hang over the door.
- Do not place explosive or flammable material in your appliance for your own safety.
- Bottles containing a high percentage of alcohol must be sealed well and placed vertically in the refrigerator.
- Do not cover the body or the top of the appliance
- Fix down the accessories in the appliance during transportation to prevent damage to them.

Electrical Safety

THIS APPLIANCE MUST BE PLUGGED INTO AN EARTHED SOCKET

- Before switching on, make sure that the voltage of your electricity supply is the same as that indicated on the rating plate. This product is designed to operate on 220 – 240V AC; 50Hz. Connection to any other power source may damage the unit.
- This product may be fitted with a non re-wireable plug. If it is necessary to change the fuse in the plug, the fuse cover must be refitted. If the fuse cover becomes lost or damaged, the plug must not be used until a suitable replacement is obtained.
- If the plug has to be changed because it is not suitable for your socket, or becomes damaged in any way, it should be cut off and an appropriate plug fitted following the wiring instructions. This should be carried out by a qualified electrician. The plug removed must be disposed of safely, as insertion into a 13 Amp socket is likely to cause an electrical hazard.

Transportation and Handling

For safe lifting, tilt the appliance backwards by no more than 45 degrees, hold the base and rear corners of cabinet. Lift the refrigerator carefully. Never use the door handles for lifting. To move the refrigerator on a flat level surface, tilt it slightly backwards and push backwards.

This unit is heavy and could cause injury – ensure there are adequate people present to move the appliance.

Installing and Switching on Your Appliance

- Operating voltage for your appliance is 220-240V at 50Hz.
- Before plugging in the power supply, ensure that the voltage on the rating label corresponds to the working voltage of your electrical system in your home.
- Insert the plug into an efficient Ground (Earth) connection. If the socket has no Ground (Earth) contact or the plug does not match, we suggest you call an authorised electrician for assistance.
- Place your appliance in an area that is not exposed to direct sunlight.
- Your appliance should be placed at least 10cm away from stoves, ovens and other heating cores.
- This appliance should never be used outdoors or left in the rain.
- When your appliance is placed next to a chest freezer or freezer, there should be at least 10cms between them to prevent humidity on the outer surface.
- The appliance must be used in the vertical position and on a flat surface.
- To level the appliance, use the adjustable feet on the rear of the appliance.
- Do not place your appliance on a carpeted surface as this will prevent adequate ventilation.
- Keep ventilation openings in the appliance enclosure or in the built in structure clear of obstruction
- This appliance should only be placed on a flat, firm surface.
- It is recommended the appliance is installed by a qualified kitchen fitter or joiner.

- Choose a dry and well-ventilated space.
- The appliance should be positioned so that the plug is easily accessible.

Before Switching On

- Before using your appliance, add a teaspoon of bicarbonate of soda to warm water and with a damp cloth wipe down all parts of the new appliance, then repeat the process with a clean damp cloth and dry. **(ensure the appliance is not connected to the power when performing this task).**
- Remove all transport tapes and foam protection pieces . Clean the interior with a cloth dampened in lukewarm soap and water. Wipe with clean water and wipe dry.
- There may be an odour when you first switch on the appliance, it will disappear when the appliance starts to cool.
- When the appliance has been positioned, adjust the feet to ensure the unit is stable. This is essential to ensure quiet running and proper door opening /closing.
- Connect to the electrical socket but do not switch the power to the refrigerator on for at least 3 hours. The coolant within the product needs time to settle after it has been transported and put in to position, failure to do this will affect the cooling performance of your appliance.
- Once the appliance has settled locate the thermostat dial on the product and set to "6" and switch on the power. The compressor will begin to work. Close the door.
- We recommend that the door is not opened for a minimum of 4 hours to allow the appliance to reach the standard operating temperature.
- You may hear faint gurgling or bubbling sounds when the refrigerant is pumped to the cooling system and through the coils or tubing at the rear of the appliance. When the compressor is in operation you may hear a slight whirring sound or pulsating noise. The thermostat controls the operation of the compressor, and you may hear a slight click as it cycles in and out (this is normal).
- To save energy, you should minimize the frequency and duration of door opening.

Product Overview

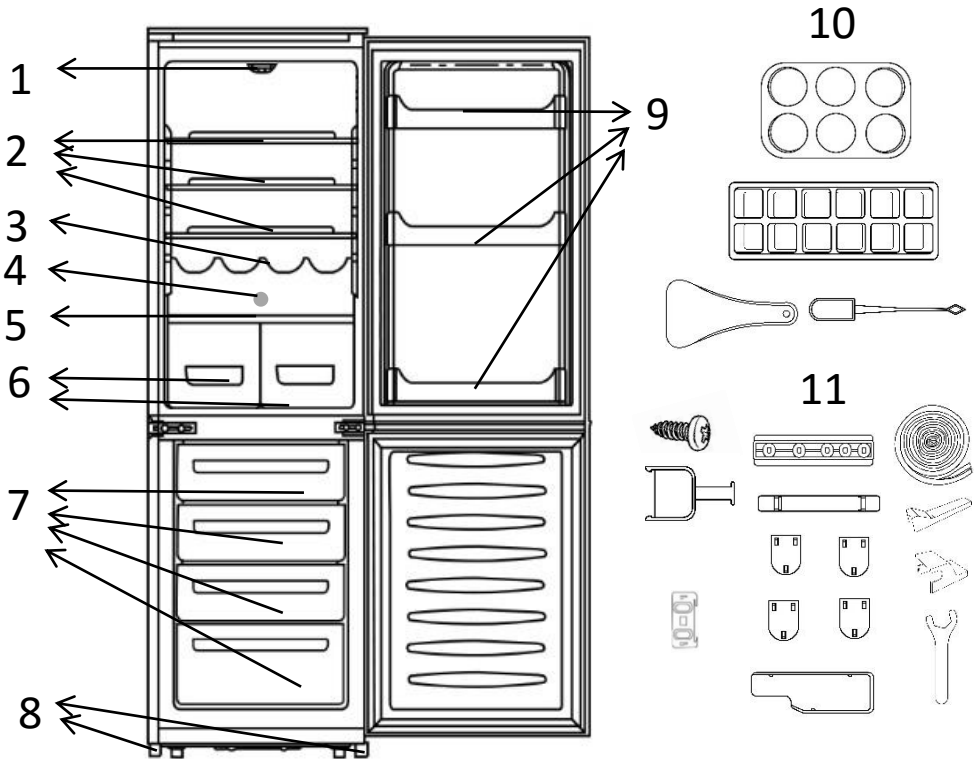

- | | | | |
|----|----------------------|-----|---|
| 1. | Light & thermostat | 8. | Feet (adjustable feet at the rear) |
| 2. | Adjustable shelves | 9. | Door racks |
| 3. | Wine rack--optional | 10. | 1 x egg tray, 1 x ice cube tray, 1 x ice scraper, drainage hole unblocker |
| 4. | Drainage hole | 11. | Installation accessories |
| 5. | Non-adjustable shelf | | |
| 6. | Crispers | | |
| 7. | Freezer drawers | | |

Unit Parts & Spare Parts

Before installation, check that all parts detailed in the product overview are present.

Usage

! Allow to stand for a minimum of 24 hours before plugging in to the mains

The temperature in the appliance is controlled by the temperature controller. Press the temperature adjustment button on the left to adjust the temperatures.

On the temperature control, 1 is the warmest and 7 is the coldest setting.

If you need to switch the appliance off press of the power button on the right.



Depending on the ambient temperature of the room the appliance is situated in, you may need to adjust the temperature control dial; in a room with a high ambient temperature the temperature control dial may need to be adjusted to a colder setting (moved towards setting 7) or in a room with a low ambient temperature the temperature control dial may need to be adjusted to a warmer setting (moved towards settings 5 or 4).

Setting 7 should be used as a rapid cool/freeze setting and should only be set 2 hours before a large amount of food is placed in the fridge. The temperature control should be put back to setting 6 after the food has been placed in the fridge. If this is not done, the temperature in the fridge compartment could fall below 0°C as the compressor will run continuously.

Once the temperature control has been set, close the door. We recommend that the door is not opened for a minimum of 4 hours to allow the appliance to reach the standard operating temperature.

Usage

! Allow to stand for a minimum of 3 hours before plugging in to the mains

Note: The standard operating temperature for the fridge compartment should be between 0°C and 4°C and the standard operating temperature for the freezer compartment should be between -18°C and -25°C.

Note: The temperature of the freshly stored food and how often the door is opened affects the temperature in the refrigerator compartment. If required, change the temperature setting.

Installation

- This appliance can be installed as a built in unit only. The clearances shown in the below drawing must be followed.
- Avoid damaging the product during installation, positioning of the appliance requires two people in order to avoid injuries or damage to the appliance.
- Your appliance should not be located in direct sunlight or exposed to continuous heat or extremes of temperature (e.g. next to a radiator or boiler). If this is not feasible, then you should install an insulation plate between the appliance and the adjacent heat source.
- You should check whether there is an electrical socket available, which will be accessible after your appliance is installed.
- Place the appliance flatly and firmly on a solid base.
- Be sure to leave enough space for the opening of the door, to avoid damage to the appliance or personal injury
- The aperture size has to be a minimum of (H)1778 x (W)560 x (D)550mm. The cabinet in which the appliance is housed in must have a ventilation recess of (W)540 x (D)50mm.
- The wooden cabinet the appliance is to be housed in must not be enclosed. The back wooden panel of the cabinet must either be removed completely or cut out in accordance with the diagram on page 12. This is to allow sufficient air circulation to cool down the condenser unit for energy efficiency.
- The accessories that are required for installation are detailed below:

20 x Torx screws



4 x Door guide

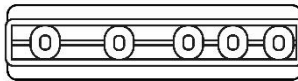

1 x Joint cover

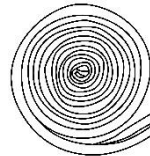

4 x Blanking covers

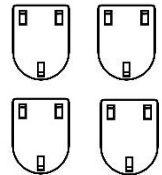

2 x Foot blanking covers

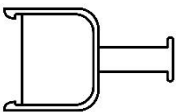

4 x Door guide cover

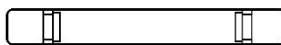

4 x Door guide holder

(pre-assembled on the door)



3 x Hinge covers

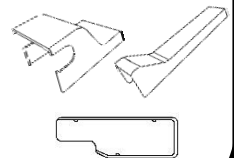

Installation

The aperture size has to be a minimum of (H)17 x (W)560 x (D)550mm. The cabinet in which the appliance is housed in must have a ventilation recess of (W)540 x (D)50mm.

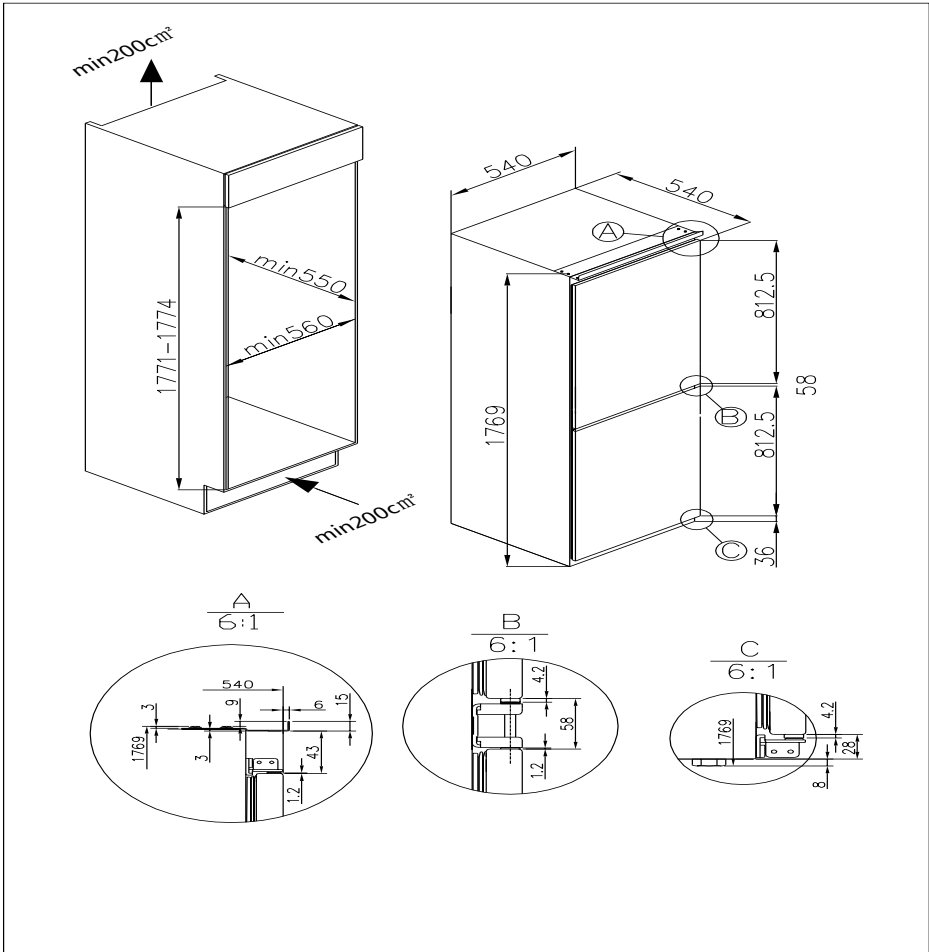

Installation

The cabinet in which the appliance is housed in must have a ventilation recess of (W)540 x (D)50mm.

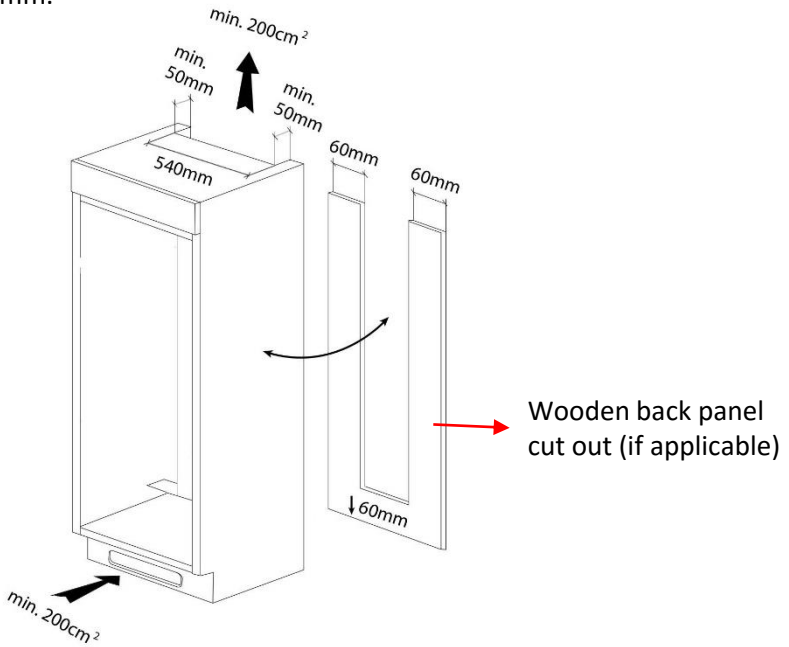

Carefully push the appliance into the housing, ensuring that the cabinet doors are able to fully close.

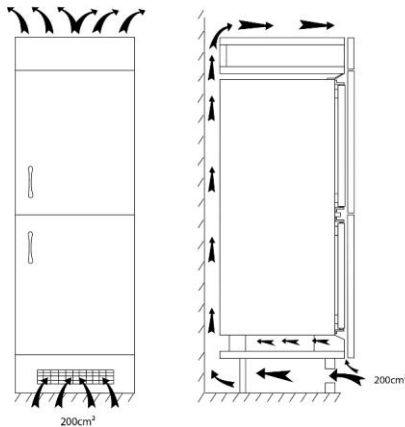

Installation

Rollout the joint cover and on the side of the appliance without the hinges press it between the appliance and the inside of the cabinet wall (start from the bottom and work upwards).

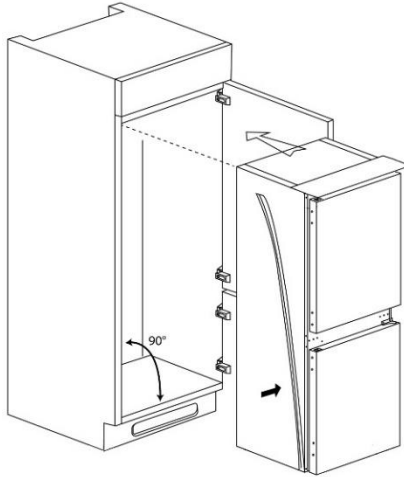

Open the door and push the side of the appliance without the hinges against the side of cabinet wall. Fix the appliance in two places, 2 torx headed screws in the top plinth at the top of the appliance and 2 torx screws in the feet (1 in each foot) at the bottom of the appliance.

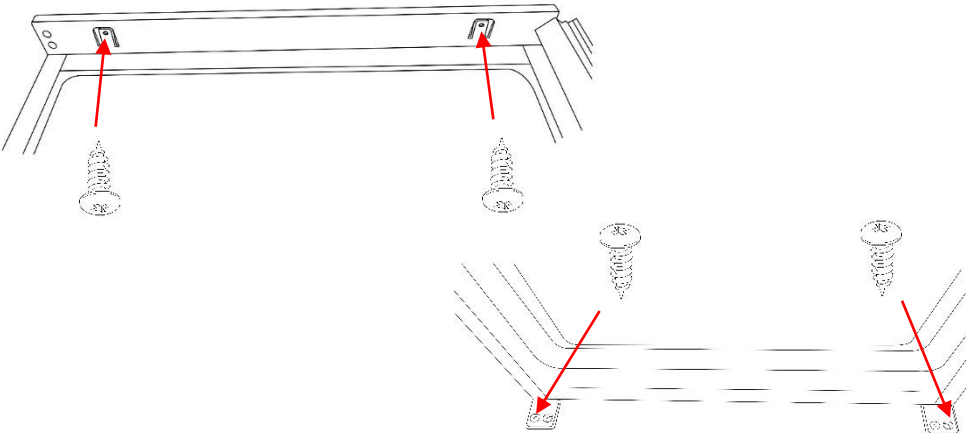

Installation

Apply blanking covers by clipping them in to place at the top metal plinth at the top of the appliance.

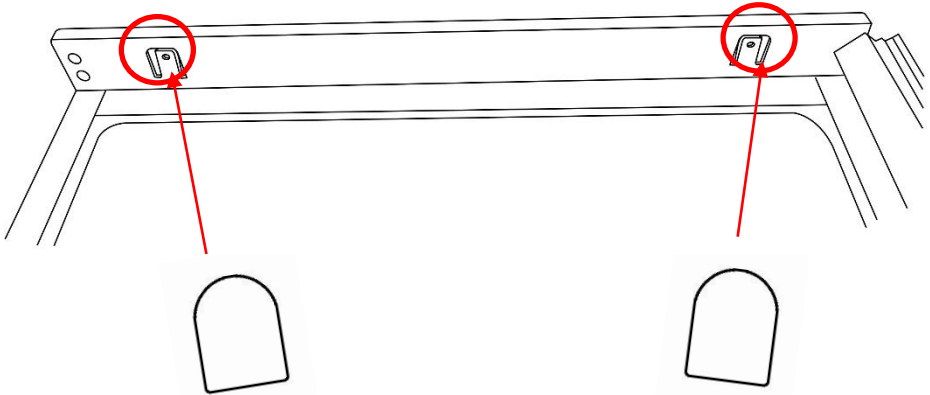

Apply a foot blanking covers by clipping them in to place on the feet at the bottom of the appliance. The plastic stem on the foot caps are there as a guide of what the distance between the product and the edge of the cabinet should be (approximately 42mm). Snap of the plastic stem after installation.

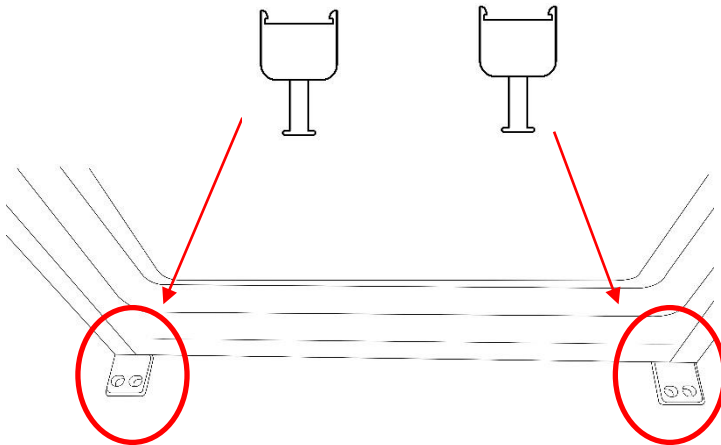

Installation – Door attachment

1. Locate parts A and B (see the below) in the bag with the installation accessories:

A. Door guide

A

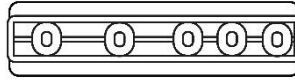

B. Door guide cover

B

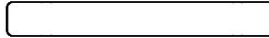

2. Open the cabinet door and the fridge door, mark on the back of the cabinet door where the top of the fridge door reaches. Place the door guide (part A) on the back of the cabinet door, in the location shown below and mark the position of first hole and the last hole on the door guide. Fix the door guide into place with 2 torx headed screws.

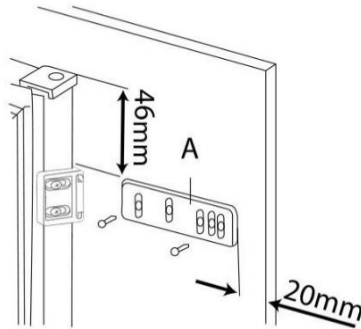

3. Clip the door guide cover (part B) on the door guide (part A) hiding the screws.

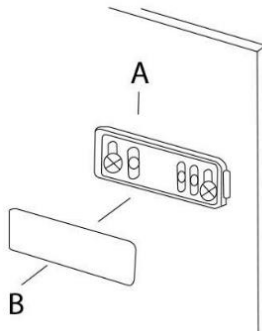

Installation – Door attachment

4. Open the appliance door and the cabinet door to 90°, remove the 2 screws from the door guide holder that is already prefixed to the door and place it on to the door guide (part A). Push the appliance door and the cabinet door together, align the holes on the door guide holder and the holes on the edge of the door and fix into place with the 2 screws that were removed previously.

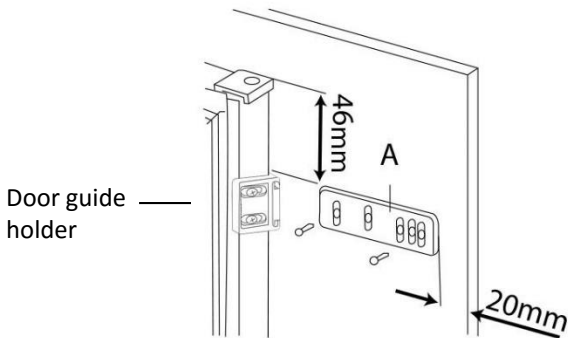

5. If any adjustment that is needed then use the clearance space in the screw slots of the door guide holder on to the door guide (part A).

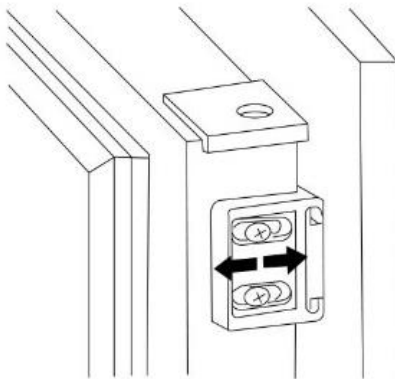

6. Check that the cabinet door closes correctly.

Installation – Door attachment

7. You will then have to repeat these steps at the bottom of the fridge door, please ensure you follow the below diagram when locating the door guide (part A) on the bottom of the fridge door.

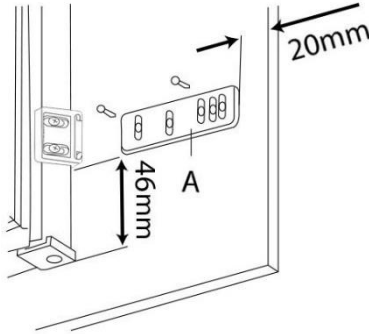

8. Repeat all steps for the freezer door, once this is done the installation should look like the below image.

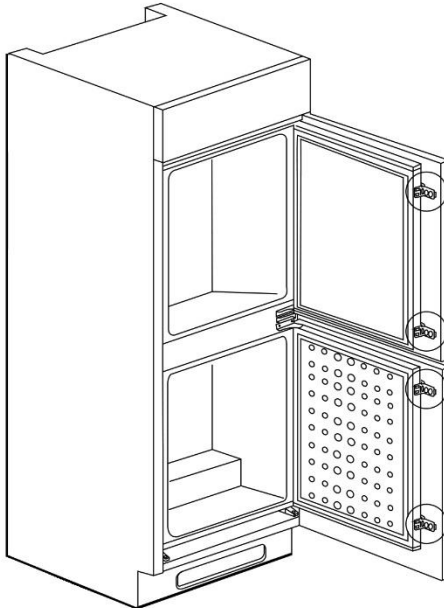

Installation – Hinge cover

1. Loose the 2 screws from the middle hinge and adjust and fasten connecting bracket so it flush with the kitchen cabinet. Fix it in place with 2 torx headed screws and screw the hinge back on to the appliance.

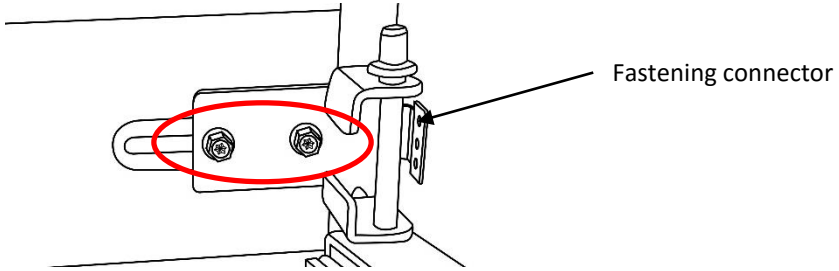

2. Slot on the hinge cover, the 2 clips on the back of the cover should slot onto the bracket of the middle hinge.

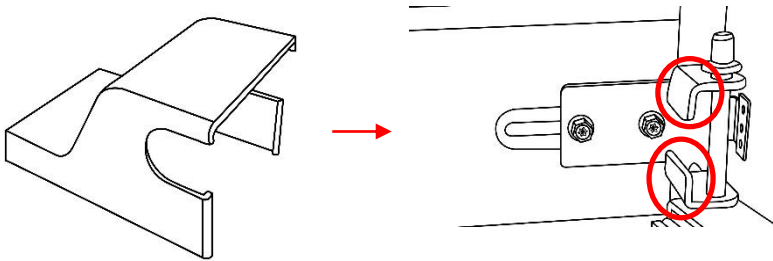

3. There are 2 other hinge covers supplied and these are for the lower and upper hinges. These can be clipped on if required.

Door Reversal

To reverse the door you will need to tilt the appliance backward to access the lower hinge which holds screws. Do not tilt the appliance more than 45 degrees and do not lay the appliance flat on its side.

For your own safety, a minimum of 2 people should lift or tilt this product.

Tools Required: Torx headed screwdriver, flat headed screwdriver and hexagonal spanner or a socket driver.

1. Unscrew the 2 screws from the upper hinge and remove the fridge door by carefully lifting it up and away from the appliance. **Do not fix the hinge to the opposite side.**

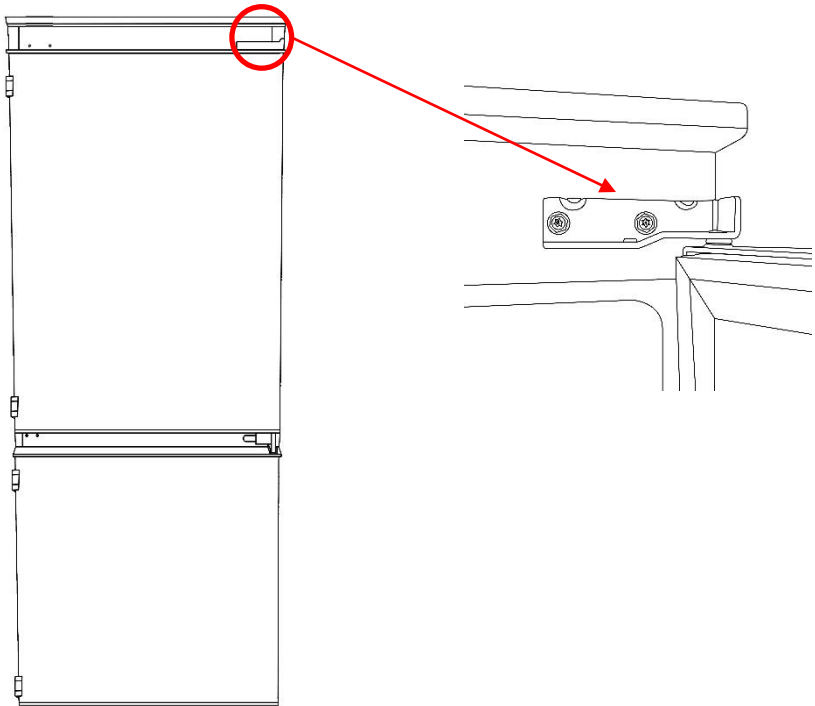

Door Reversal

2. Remove the hinge pin and unscrew the 2 screws from the middle hinge. Remove the hinge and the freezer door by carefully lifting it up and away from the appliance. **Do not fix the hinge to the opposite side at this stage, please see step 6.**

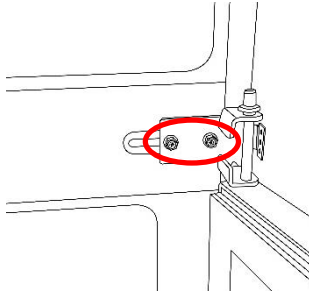

3. Unscrew the 2 screws from the lower hinge and remove the hinge. **Do not fix the hinge to the opposite side at this stage.**

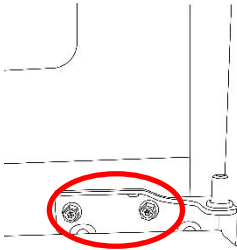

4. Remove all of the screw cap covers on the opposite side of the appliance from where the hinges have just been removed. Remove the hinge plugs on the top of the freezer door and the top and bottom of the fridge door and fix them to the opposite side. Fix the screw caps that were removed on to the opposite, if needed there are spare screw caps supplied.

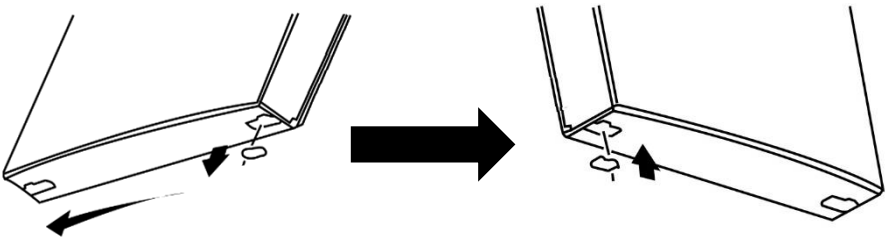

Door Reversal

5. Flip over the **upper** hinge 180° (so the pin is pointing upwards) and fix on to the opposite side at the bottom of the appliance. Place the freezer door back on to the lower hinge.

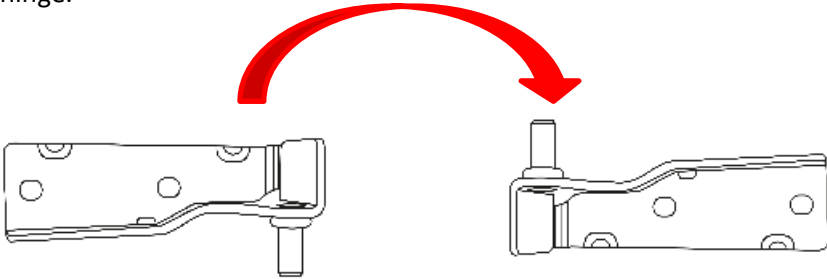

6. Flip over the middle hinge (by 180°) and put the hinge pin into the middle hinge (ensuring the fixed washer is at the top) and place the bottom part of the pin into the top of the freezer door. Put the fastening connector on the hinge and screw the middle hinge and fastening connector back onto the opposite side the fridge. **You must ensure the freezer door is aligned horizontally and vertically, so that the seals are closed on all sides before finally tightening.**

Fixed washer

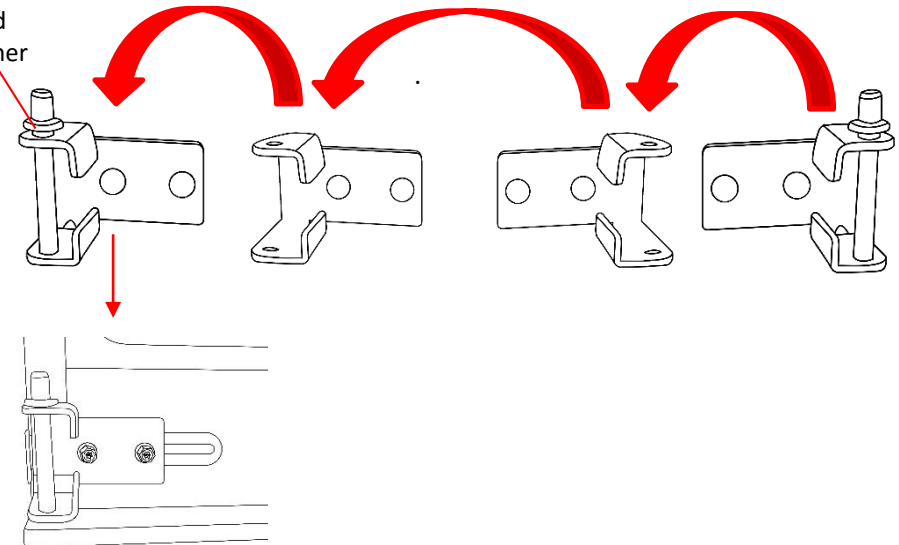

Door Reversal

7. Place the fridge door back on to the middle hinge, flip the **lower** hinge 180° (so the pin is pointing downwards) and put the pin of the hinge into the top of the door and fix it in to place. **Ensure the fridge door is aligned horizontally and vertically so that the seals are closed on all sides before finally tightening the top hinge pin.**

Remove the 4 door guide holders from side of the doors and fix them on to the opposite side.

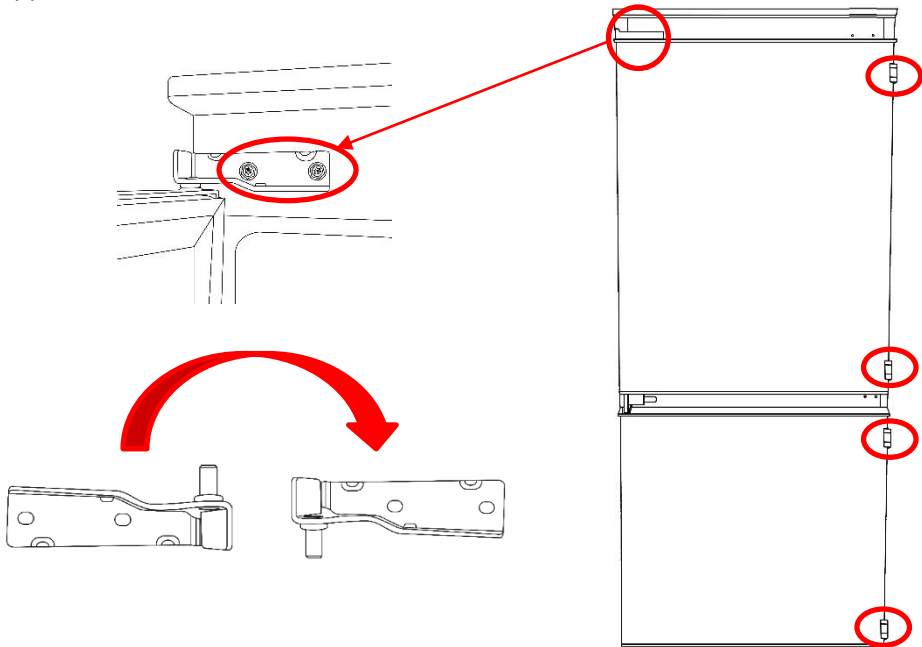

Replacing the Light

The light is an energy efficient, long life LED. Therefore should not need replacing throughout the life of the product however if it does it has to be replaced by a qualified engineer.

Energy Saving Advice

- Do not install the appliance close to sources of heat, such as a cooker, dishwasher or radiator.
- Locate the appliance in a cool well-ventilated room and make sure that the air vents are clear.
- Try to avoid keeping the doors open for a long time, as warm air will enter the cabinet and may cause a build-up of ice as well as affecting the energy consumption. Ensure there are no obstructions preventing the doors from closing properly.
- Ensure that the door seals are clean and there are no tears or splits.
- Keep the most perishable foods, (those with a short shelf-life, such as cooked meats), in the coldest part of the fridge. The Salad Crisper Box is the warmest part of your fridge and should be used for vegetables, salads and fruits etc.
- Do not overload the appliance: the cooling air that circulates and keeps the appliance cold gets blocked, and pockets of warm air form.
- Do not put hot food into the fridge or freezer – let it cool down first.

Freezer Storage Advice

- Store fresh food in airtight boxes or wrap in bags or foil which are suitable for freezing.
- Do not allow frozen food to come in to direct contact with food to be frozen.
- Pre-frozen food must be placed in the freezer as quickly as possible after purchasing.
- To prevent frost damage to fresh vegetables or fruits they must be processed appropriately before being placed into the freezer compartment.
- You must always follow the storage guidelines printed on all food packaging. However, below is some suggested maximum storage times at -18°C (4 star freezer rating) for a variety of foods:
 - Fresh meat & poultry – up to 12 months
 - Cooked meat – up to 2 months
 - Fresh fish – up to 6 months
 - Fruit & vegetables – up to 12 months
 - Bread & cakes – up to 6 months

Power Failure

If there is a power failure during the storage of frozen foods, keep the door closed. If the temperature within your freezer should rise, do not refreeze the food without checking it's condition.

- **Ice Cream:** Once thawed should be discarded.
- **Fruit and Vegetables:** If soft should be cooked and used up.
- **Bread and Cakes:** Can be refrozen without danger.
- **Shellfish:** Should be refrigerated and used up quickly.
- **Cooked Dishes:** i.e. casseroles should be refrigerated and used up.
- **Large Pieces of Meat:** Should be refrigerated and used up quickly
- **Small Joints:** Should be refrigerated and used up quickly
- **Chicken:** Should be refrigerated and used up quickly

Maintenance & Cleaning

Disconnect the appliance from the power supply before cleaning.

Internal Cleaning

- Do not pour water over the appliance.
- The cavity should be cleaned periodically using a solution of bicarbonate of soda and lukewarm water (5ml to 0.5 litre of water)
- Clean the accessories separately with soap and water. Do not put them in the dishwasher.
- Do not use abrasive products, detergents or soaps.
- After washing, rinse with clean water and dry carefully.
- When you have finished cleaning reconnect the plug with **dry hands**.

External Cleaning

- Wash the outer cabinet with warm soapy water. Do NOT use abrasive products.
- There are sharp edges on the underside of the product so care should be taken when cleaning.
- Once or twice a year dust the rear of the appliance and the compressor at the back of the appliance, with a brush or vacuum cleaner, as an accumulation of dust will affect the performance of the appliance and cause increased energy consumption.

When the appliance is not in use

When the appliance is not in use for long periods, disconnect from the electricity supply, empty all of the food and clean the inside. Leave the door open to prevent the build-up of odours.

Maintenance & Cleaning

Defrosting

Note: Care must be taken when performing the following procedure.

Defrost twice a year or when a frost layer of approximately 7 mm (1/4") has formed.

- 2 hours before the defrosting process, set the thermostat knob at the "7" position to make sure the food is at the lowest temperature before removing the frozen foods. All food should be wrapped in several layers of newspaper and stored in a cool place (e.g. fridge or larder).
- Place several layers of new paper or towels underneath and next to the freezer door/compartment
- Switch off the appliance at the socket outlet and pull out the mains plug.
- Remove all drawers, baskets, etc. and leave the door or lid open. Containers of warm water (not hot) may be placed carefully in the freezer to speed up the defrosting process.
- Never use hairdryers, electrical heaters or other such electrical appliances for defrosting.
- When the ice has melted, clean and dry the interior. Wipe up any spillages that may have occurred.
- Switch the appliance on and replace any frozen food



Never use sharp metal tools as it may damage the appliance.

Never use an electrical heater, this may cause an electric shock.

Trouble shooting

Problem	Solution
The fridge/freezer doesn't work	Check that the appliance is switched on.
	Check that there has not been a power cut.
	Check that the plug is not faulty.
	Check that the fuse has not blown.
	Check that the voltage is correct for the appliance.
	Are there any faults with the socket? For this purpose, try the plug of your appliance by connecting it to a socket which you are sure is working.
The temperature inside the appliance is not cold enough	Check that there is not too much food in the appliance.
	Check that the thermostat is set to a suitable temperature.
	Check that the appliance is not placed in direct sunlight, or too near to a heating source.
	Check that the ambient temperature is within the operation limits of the appliance.
	Are the doors of the appliance opened frequently? Once the door is opened, the humidity found in the air in the room enters the appliance, especially if the humidity levels in the room are very high. The more frequently the door is opened in humid conditions the more chance of the build up of moisture.
The temperature within the appliance is too cold.	Increase the working temperature by adjusting the thermostat to a lower setting.
	The highest setting should only be used as a rapid cool setting and should only be set 2 hours before a large amount of food is placed in the fridge. If this is not done the temperature in the fridge compartment could fall below 0°C as the compressor will run continuously.
The inner surfaces of the appliance are wet	Caused by condensation - dry the inside of the appliance.
The outer surfaces of the appliance are wet	Caused by condensation - dry the outer of the appliance carefully.

Trouble shooting

Problem	Solution
Smell/odour	<p>Check all the food and drink that is in the fridge is in date and correctly packaged. If it isn't then it should be removed immediately or repackaged.</p> <p>Check for spillages on each shelf, rack and drawer. You may need to remove the drawers to check that no spillages have settled underneath them. As spillages that have not been cleaned and have been left can cause smells and unwanted odours.</p> <p>Check the drainage pipe is not clogged or the drip tray at the back of the appliance is full. The pipe can be cleared by pouring hot water through, but you must ensure the appliance is turned off, the plug is removed from the socket and a jug or bucket is in place to catch the flow of water.</p>
The doors do not close properly	<p>Ensure there are no obstructions preventing door closure.</p> <p>Check the door compartments and shelves are correctly in place.</p> <p>Check the door seal is not warped or torn.</p> <p>Check the appliance is level.</p>
Unusual noises	<p>Check that the appliance is on a flat, level surface and is stable.</p> <p>Check the spacing's around the appliance and ensure it is not touching other items.</p> <p>Bubbling and gurgling sound: • This noise is emitted as the coolant fluid flows through the pipes within the system. This is normal.</p> <p>Water flowing sound: • This is the normal sound of water flowing into the drain trough during the defrosting process.</p> <p>If the appliance is operating noisily (compressor noise): This is normal. This noise indicates that the compressor is operating normally. As the compressor is being energized, it might run a bit more noisily for a short period of time.</p>

Connection to the Mains Supply

WARNING- THIS APPLIANCE MUST BE EARTHED

This appliance is designed to operate from a mains supply of AC220V - 240V; 50HZ. Check that the voltage marked on the product corresponds with your supply voltage.

For UK use only – Plug fitting details (where applicable):

As the colours of the wires in the mains lead of this appliance may not correspond with the coloured markings identifying the terminals in your plug, proceed as follows:

The GREEN/YELLOW wire is the EARTH and must be connected to the terminal which is marked with the letter E or by the earth symbol or coloured GREEN or GREEN/YELLOW.

The BLUE wire is the NEUTRAL and must be connected to the terminal marked with the letter N or coloured BLACK.

The BROWN wire is the LIVE wire and must be connected to the terminal marked with the letter L or coloured RED.

Always ensure that the plug cord grip is fastened correctly.

If a 13A (BS1363) fused plug is used it must be fitted with a 13amp fuse conforming to BS1362 and be BSI or ASTA approved.

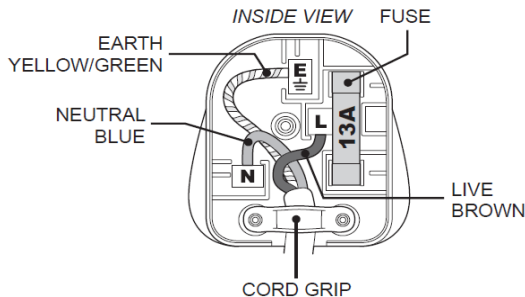

Guarantee

Technical Specification

Model number

Rated Voltage 220V – 240V ~ 50Hz

Capacity 228L

External Dimensions(HxWxD) 17 mm x 540mm x 540mm

POWERPOINT STANDARDMANUFACTURERWARRANTY

TERMS AND CONDITIONS

This appliance was supplied by Shomar Ltd, Dublin. Combining years of knowledge and experience with our commitment to producing high quality appliances is what make us the country's best, fully Irish owned, Domestic Appliance Distributor. We provide all after sales service from our Headquarters in Dublin.

12 Month Warranty

This Warranty is for 12 Months from Date of Purchase and covers both Parts & Labour. Any complaints that occur during normal use of these appliances will be repaired free of charge provided the appliance has been used and maintained in accordance with the Terms and Conditions.

If a repair to your appliance is necessary evidence of purchase will be required for a call to be covered by your Warranty.

Two-year Warranty

To avail of the second year free warranty you must register your new appliance with Shomar Ltd. Registering your appliance will also allow us to contact you in the unlikely event that a modification is required. In case of an insurance loss such as theft, fire or flood, your registration will serve as proof of purchase. Scan our QR to register your warranty -



www.powerpointappliances.ie

Terms and Conditions

The Warranty only covers the appliance for use in a normal domestic environment. Institutional use or commercial use is not covered. (To obtain a commercial Warranty on your appliance contact us on service@shomar.ie for more details)

The following is not covered by the Warranty:

- Complaints due to the use of incorrect voltage.
- Failure of the water supply
- Failure of the electricity supply
- Failure to operate the appliance in line with the guidelines set out in the instruction manual.
- Damage to the appliance or its components however caused.
- Consumable items. E.g. Fuses, bulbs, broken glass, Knobs, Plastics.
- Blockages of Filters, drainage systems, soap dispensers etc

Note:

- Repairs or modifications carried out by anyone other than Shomar authorised agents will deem the Warranty Null and Void. Please visit www.powerpointappliances.ie to obtain information on authorised agents.
- All Gas appliances must by law be fitted by a Registered Gas Installer. For further details see WWW.RGI.IE
- Built In appliance installation and reversing the door hinges must be undertaken by a competent person.
- If in any doubt about the installation of our domestic appliances please email us for more details.service@shomar.ie

How to log a service call:

If in the event you need to log a service call for your appliance you can contact our service department on Ph: 01-4505327 (during working hours)

Email service@shomar.ie

Go online www.powerpointappliance.ie

This Warranty does not in any way diminish or affect your statutory rights in connection with the product. This Warranty is in addition to your statutory rights as a consumer. If you have any questions about these rights, please contact the retailer from which you purchased the product. In certain circumstances, it is possible that your statutory rights may offer additional or higher levels of protection than those offered under the terms of this Warranty.

This Warranty applies only to the cost of repairing the product. To the extent permitted by law, the Manufacturer does not accept and will not be held liable for any financial loss incurred in connection with the failure of any product to operate in accordance with the expected standards. Such financial loss includes but is not limited to loss arising from:

- Food Loss
- Time taken from work
- Damaged clothing or other items
- Laundry costs
- Meals from Restaurant /Takeaways
- General Compensation for Inconvenience

Does PowerPoint offer replacements?

This is a repair-only Warranty. On occasion, the Manufacturer may at its sole discretion, replace your product with a new product instead of carrying out a repair. In the unlikely event we cannot repair your appliance it will be replaced free of charge, replacement will be authorised and provided by the retailer upon contact from the manufacturer.

Any costs related to disconnecting the faulty product and installing the replacement product will not be borne by the Manufacturer unless previously agreed to in writing. The original Warranty will continue to apply to the replacement product; the new product will not come with a new Warranty.

Will I be charged for the repairs?

It is the responsibility of the consumer to provide proof of purchase to the Engineer to ensure your product is covered by this warranty. The Manufacturer reserves the right to charge for service call if:

- You cannot provide proof of purchase that your product is covered by this Warranty.
- The engineer finds that there is no fault with your product.
- That your product has not been installed or operated in accordance with the User Manual.
- That the fault was caused by something other than faulty materials, defective components, or manufacturing defects.

- For missed appointments.

Payment is due immediately upon the Engineer providing you with an invoice. The Manufacturer reserves the right to terminate the Warranty if you fail to pay the costs for the service call.

The spare part availability of this appliance is 10 years. During this time, original spare parts will be available to operate the appliance properly.

This appliance was supplied by Shomar Ltd Dublin. If you would like to contact us in relation to your product for service or spare parts we can be contacted on 01-4505237 or service@shomar.ie.

To register your warranty please visit our website www.powerpointappliances.ie



www.powerpointappliances.ie

CE



This symbol is known as the 'Crossed-out wheellie bin Symbol'. When this symbol is marked on a product/batteries, it means that the product/batteries should not be disposed of with your general household waste. Only discard electrical/electronic/battery items in separate collection schemes, which cater for the recovery and recycling of materials contained within. Your co-operation is vital to make sure the success of these schemes and for the protection of the environment. For your nearest disposal facility, visit www.recycle-more.co.uk or ask in store for details.

We reserve the right due to possible changes to design to alter the instruction manual without prior notice.